

# Autoencoders

David I. Inouye

# Outline

- ▶ Autoencoder basics
- ▶ Autoencoder constraints and formulations
  - ▶ Undercomplete autoencoder
  - ▶ Sparse autoencoder
  - ▶ Denoising autoencoders
- ▶ Probabilistic autoencoders
- ▶ Variational Autoencoder (VAE)
  - ▶ Definition and objective derivation
  - ▶ Evidence Lower Bound (ELBO)
  - ▶ Reparameterization trick

Autoencoders map an input to a latent code (encoder) and map this latent code back to the input (decoder)

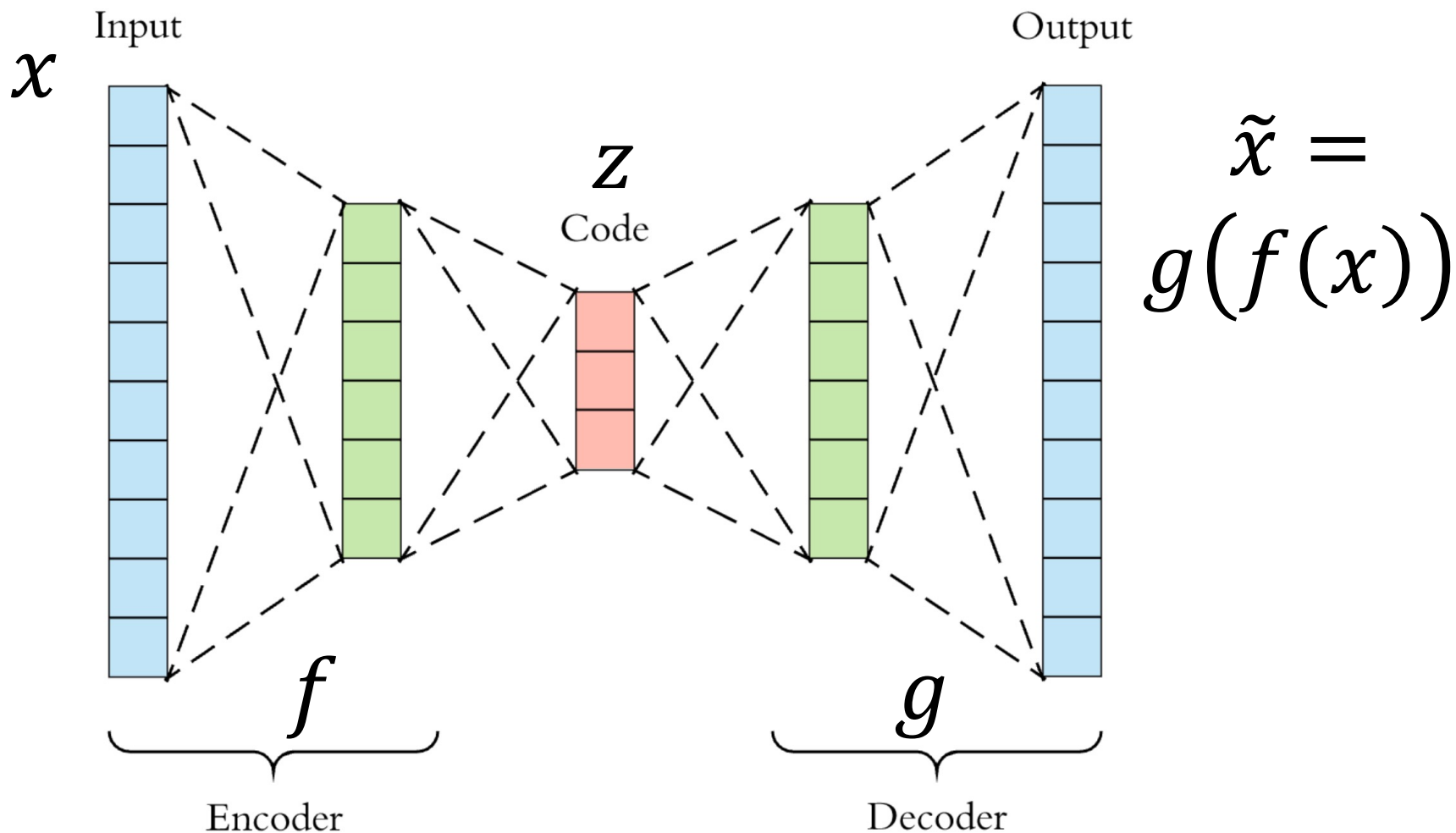

<https://towardsdatascience.com/generating-images-with-autoencoders-77fd3a8dd368>

The optimization problem is to fit the encoder and decoder simultaneously to reconstruct output

- ▶ More formally, the autoencoder objective is:

$$\min_{f,g} \mathbb{E}[L(x, \tilde{x})]$$
$$\min_{f,g} \mathbb{E} \left[ L \left( x, g(f(x)) \right) \right]$$

- ▶ One example is using Mean Squared Error loss

$$\min_{f,g} \mathbb{E} \left[ \|x - g(f(x))\|_2^2 \right]$$

If there are no constraints on the encoder and decoder than the identity function works perfectly...

▶ Suppose  $f(x) = x$  and  $g(x) = x$

▶ Then we know that

$$\begin{aligned} & \min_{f,g} \mathbb{E} \left[ \|x - g(f(x))\|_2^2 \right] \\ &= \min_{f,g} \mathbb{E} [\|x - x\|_2^2] = 0 \end{aligned}$$

▶ And since all terms are positive, this is the global minimum

▶ Trivial/useless...What can we do?

Adding constraints to  $f$ ,  $g$  or  $z$  can often produce interesting properties of  $z$

- ▶ Undercomplete autoencoders assume that the latent space has lower dimension, i.e.,  $k < d$

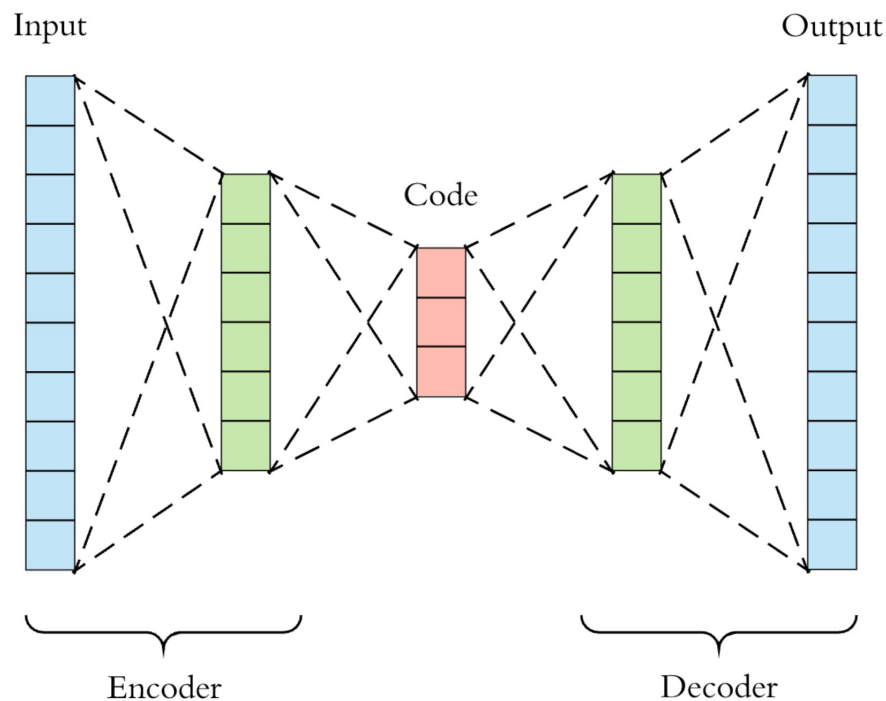

The undercomplete and linear autoencoder is closely related to PCA

► Formally

► Let  $z = f(x) = Ax + b, z \in \mathbb{R}^k$

► Let  $\tilde{x} = g(z) = Bz + c$

► Let  $L(x, \tilde{x}) = \mathbb{E}[\|x - \tilde{x}\|_2^2]$

► One solution can be derived from PCA though other (closely-related) solutions exist

► Autoencoders are “non-linear” PCA

# Why might we want a non-linear autoencoder?

## Non-linear dimensionality reduction

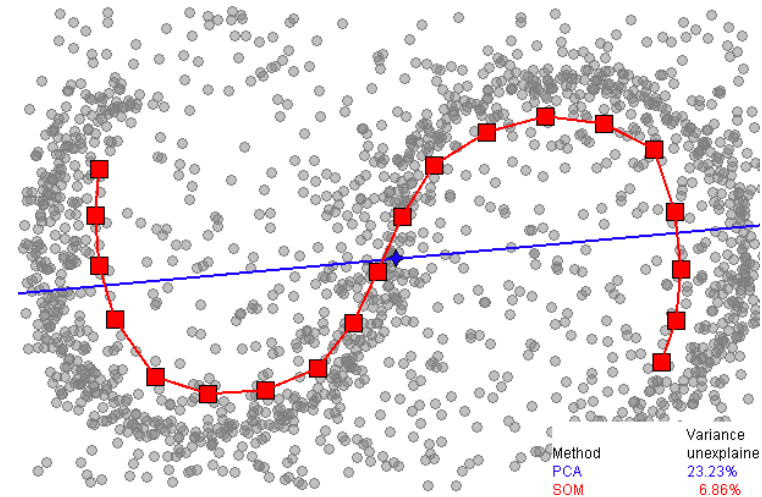
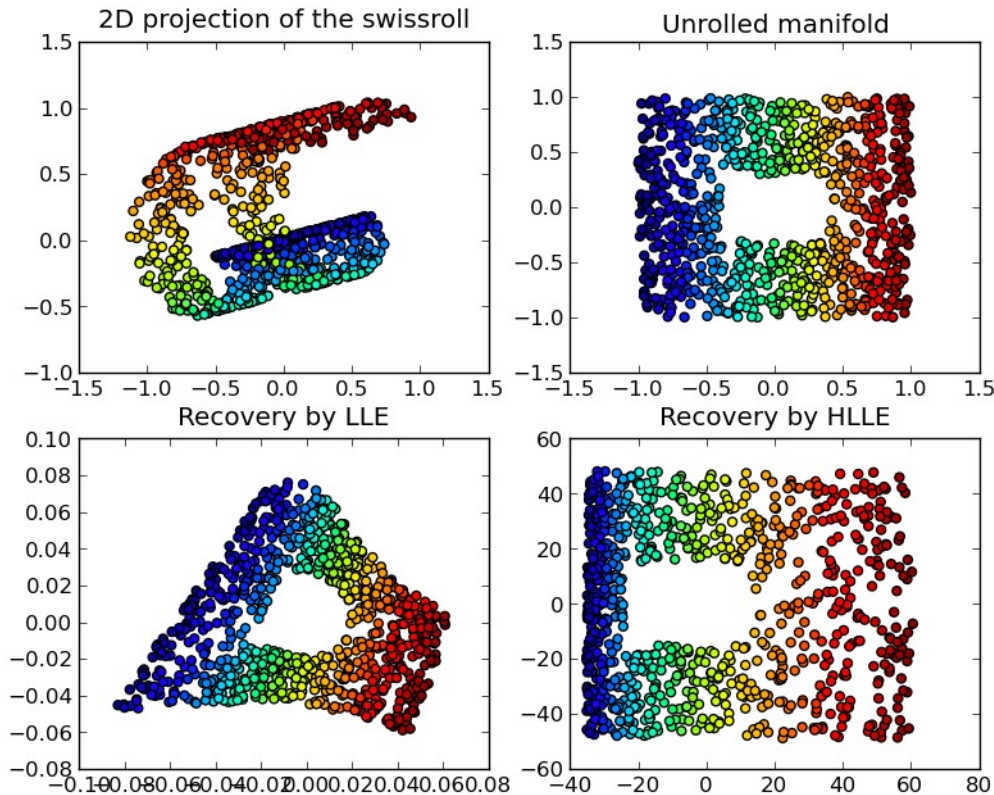

[https://en.wikipedia.org/wiki/Nonlinear\\_dimensionality\\_reduction](https://en.wikipedia.org/wiki/Nonlinear_dimensionality_reduction)



Sparse autoencoders add a penalty that the latent space is sparse

- ▶ Add a regularization term to latent variables

$$\min_{f,g} \mathbb{E} \left[ L \left( x, g(f(x)) \right) + \lambda \|f(x)\|_1 \right]$$

- ▶ This creates **data-dependent** sparsity

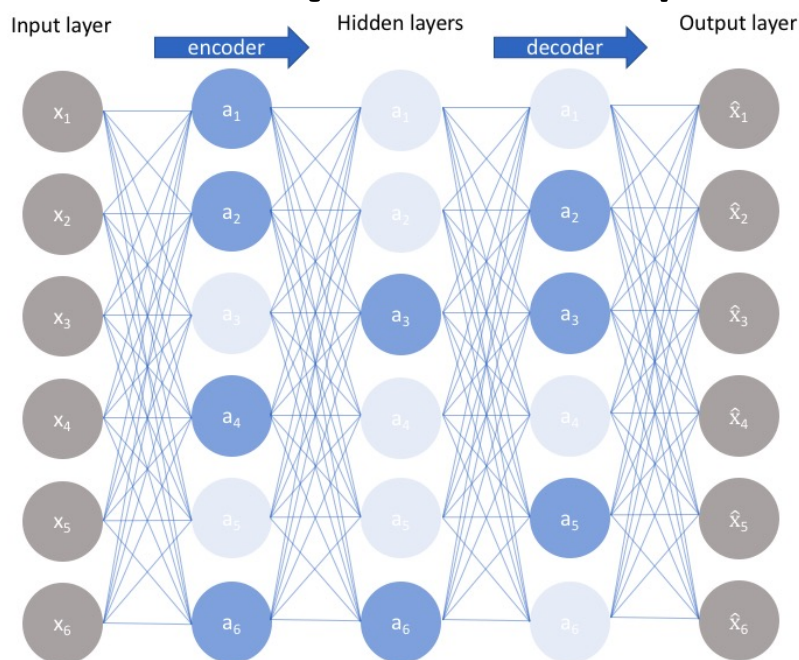

# Denoising autoencoders force functions to learn to remove noise rather than copy the input

- ▶ Add noise to the input so that copying input is not possible

$$\min_{f,g} \mathbb{E}_{x,\epsilon} \left[ L \left( x, g(f(x + \epsilon)) \right) \right], \text{ where } \epsilon \sim \mathcal{N}(\mu, \sigma I)$$

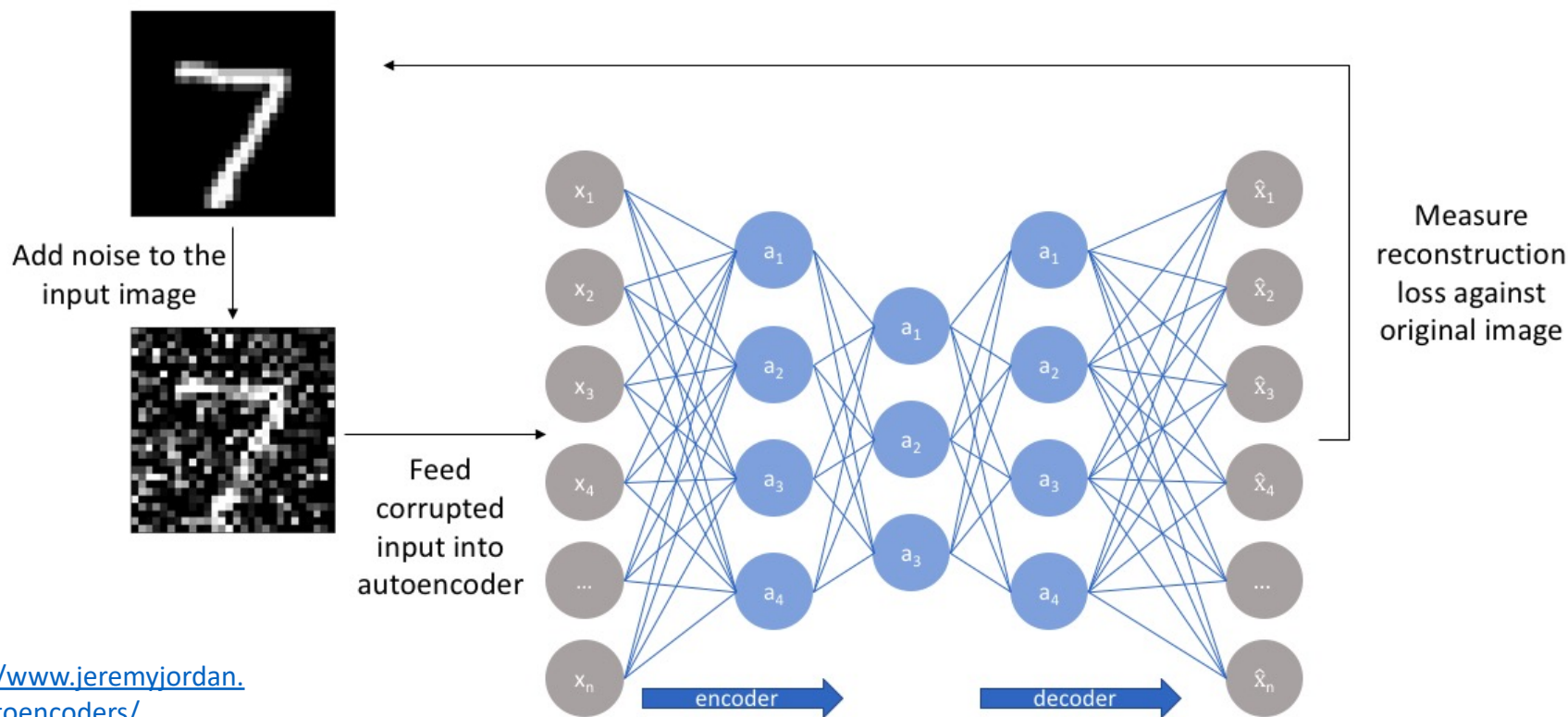

# Denoising autoencoders can be shown to learn the structure of the distribution

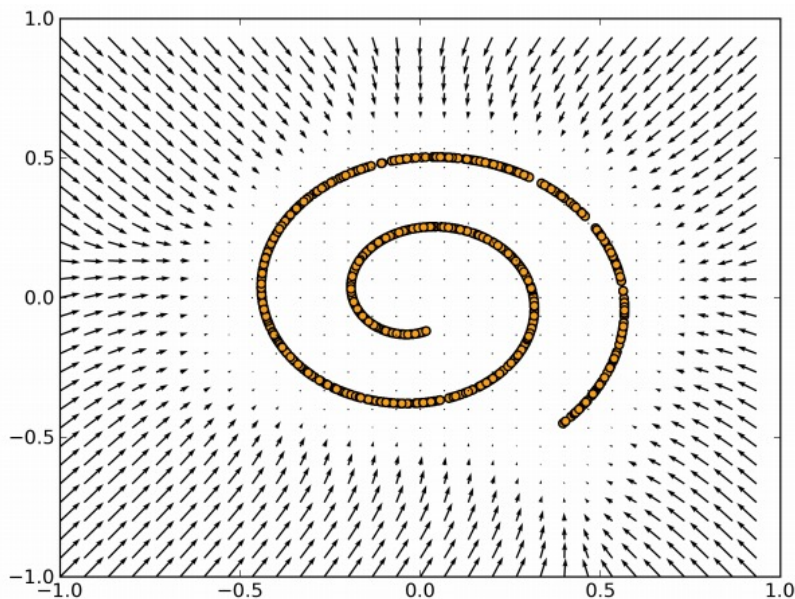

Vector field that pushes corrupted data back to manifold as learned by DAE

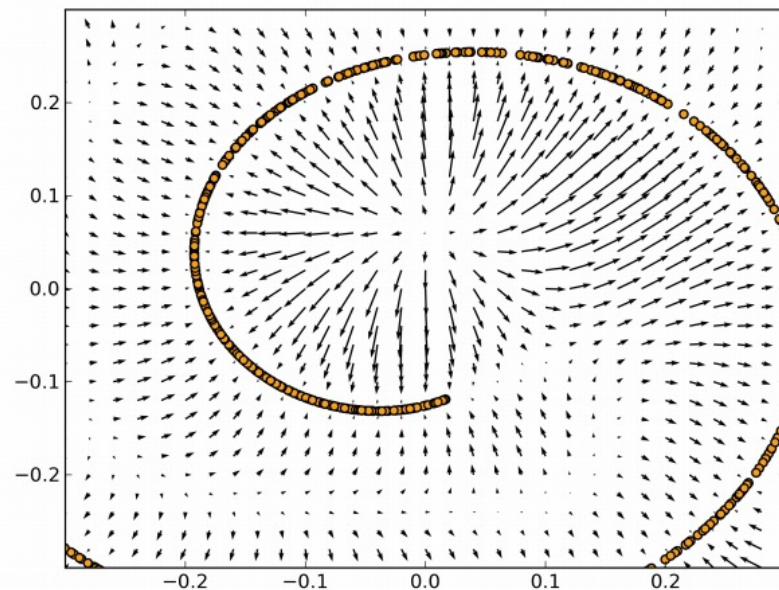

Zoomed in view

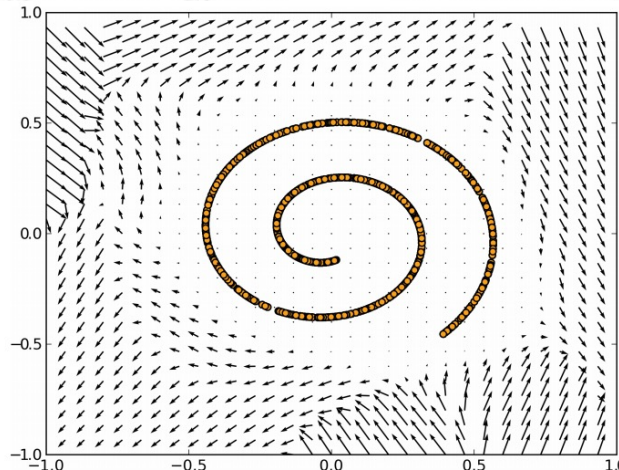

May misbehave outside data area in practice

<https://arxiv.org/pdf/1211.4246.pdf>

# Autoencoders can also use non-deterministic or probabilistic mappings

- ▶ The outputs are **distributions** instead of a points

- ▶ Encoder/decoder output the **parameters** of distribution

- ▶ Probabilistic mappings

- ▶ Replace encoder  $f(x)$  with  $q_f(z|x) = \mathcal{N}(z; \mu = f(x), \Sigma = I)$

- ▶ Replace decoder  $g(z)$ , with  $p_g(x|z) = \mathcal{N}(x; \mu = g(z), \Sigma = I)$

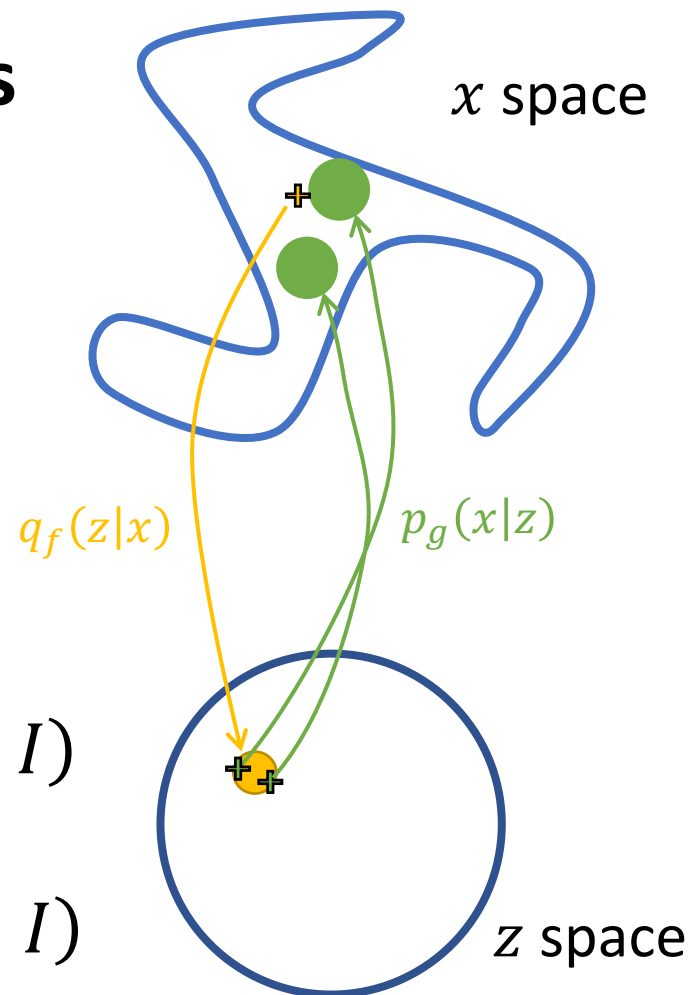

Vanilla probabilistic autoencoder could minimize expected negative log likelihood of training data

$$\min_{f,g} \mathbb{E}_{p_{\text{data}}(x)} \left[ \mathbb{E}_{q_f(z|x)} [-\log p_g(x|z)] \right]$$

- ▶ Fact: If  $\epsilon \sim \mathcal{N}(0, I)$  and  $z_\ell = \mu + \epsilon$ , then  $z_\ell \sim \mathcal{N}(\mu, I)$ .
- ▶  $\widehat{\mathbb{E}}_{p_{\text{data}}(x)} \left[ \widehat{\mathbb{E}}_{q_f(z|x)} [-\log p_g(x|z)] \right]$  (Empirical expectation)
- ▶  $= \frac{1}{n} \sum_i \frac{1}{m} \sum_\ell -\log p_g(x_i | z_i^\ell)$
- ▶  $= \frac{1}{n} \sum_i \frac{1}{m} \sum_\ell -\log \exp \left( -\frac{1}{2} \|x_i - \mu_i^\ell\|_2^2 - \frac{d}{2} \log 2\pi \right)$
- ▶  $= \frac{1}{n} \sum_i \frac{1}{m} \sum_\ell \frac{1}{2} \|x_i - \mu_i^\ell\|_2^2 + c$  ( $c$  is constant)
- ▶  $= \frac{1}{n} \sum_i \frac{1}{m} \sum_\ell \frac{1}{2} \|x_i - g(z_i^\ell)\|_2^2 + c$
- ▶  $= \frac{1}{n} \sum_i \frac{1}{m} \sum_\ell \frac{1}{2} \|x_i - g(f(x_i) + \epsilon_i^\ell)\|_2^2 + c$  (Remember fact above)
- ▶  $= \frac{1}{n} \sum_i \frac{1}{2} \|x_i - g(f(x_i) + \epsilon_i)\|_2^2 + c$  (let  $m = 1$ , where  $\epsilon_i \sim \mathcal{N}(0, I)$ )

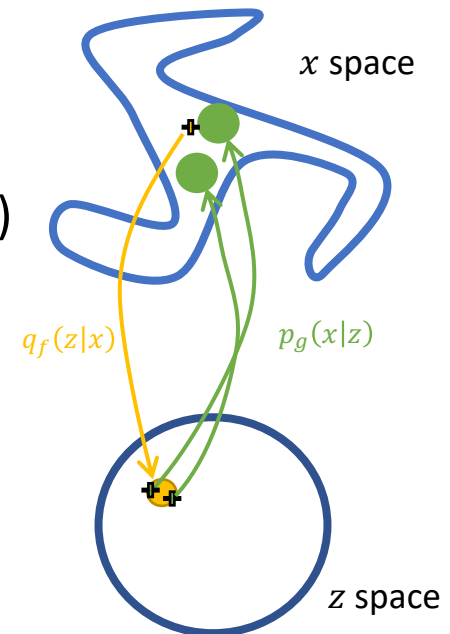

$$q_f(z_i^\ell | x_i) = \mathcal{N}(z; \mu_i = f(x_i), \Sigma = I)$$

(Remember fact above)

Notice the reconstruction term is like AE except for added noise if Gaussian is used.

# Comparison between autoencoders

- ▶ MSE autoencoder (AE)

$$\min_{f,g} \frac{1}{n} \sum_i \|x_i - g(f(x_i))\|_2^2$$

- ▶ Sparse autoencoder

$$\min_{f,g} \frac{1}{n} \sum_i \|x_i - g(f(x_i))\|_2^2 + \lambda \|f(x_i)\|_1$$

- ▶ Gaussian denoising autoencoder (DAE)

$$\min_{f,g} \frac{1}{n} \sum_i \|x_i - g(f(x_i + \epsilon_i))\|_2^2, \quad \epsilon_i \sim \mathcal{N}(\mu, \sigma I)$$

- ▶ Vanilla Gaussian probabilistic autoencoder (with 1 sample in latent space)

$$\min_{f,g} \frac{1}{n} \sum_i \|x_i - g(f(x_i) + \epsilon_i)\|_2^2, \quad \epsilon_i \sim \mathcal{N}(0, I)$$

- ▶ Regularized Gaussian probabilistic autoencoder

$$\min_{f,g} \frac{1}{n} \sum_i \|x_i - g(f(x_i) + \epsilon_i)\|_2^2 + \lambda \|f(x_i)\|_2^2, \quad \epsilon_i \sim \mathcal{N}(0, I)$$

This is special case of Gaussian variational autoencoders (VAE) called Constant Variance VAEs.

Ghosh, P., Sajjadi, M. S., Vergari, A., Black, M., & Schölkopf, B. (2019). From variational to deterministic autoencoders. *arXiv preprint arXiv:1903.12436*.



# Variational Autoencoders (VAE) are one of the most common probabilistic autoencoders

- ▶ Method produces both
  - ▶ Probabilistic encoder/decoder for dimensionality reduction/compression
  - ▶ **Generative model** for the data (AEs don't provide this)
- ▶ **Generative model** can produce fake data

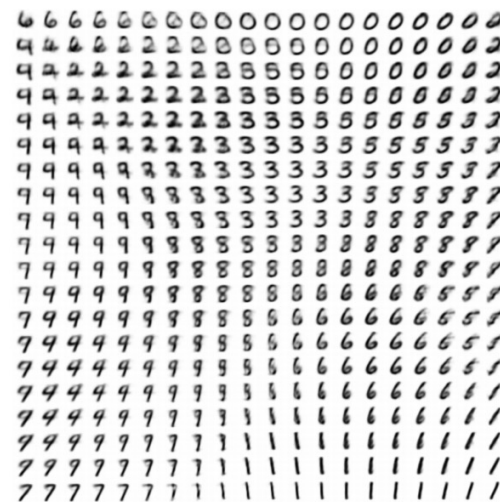

(b) Learned MNIST manifold



(a) 2-D latent space      (b) 5-D latent space      (c) 10-D latent space      (d) 20-D latent space

Figures and reference from Kingma, D. P. and M. Welling (2014). "Auto-Encoding Variational Bayes". *International Conference on Learning Representations*.

VAEs have inference and generative networks with an assumed prior distribution on  $z$

► Generative model

$$z \sim p_g(z) = \mathcal{N}(0, I)$$

$$x \sim p_g(x|z)$$

► MLE is intractable

$$\log p(x; g) = \log \int_z p_g(z) p_g(x|z) dz$$

Observed likelihood intractable

► Add encoder/inference model to help

$$x \sim p_{\text{data}}(x)$$

$$z \sim q_f(z|x)$$

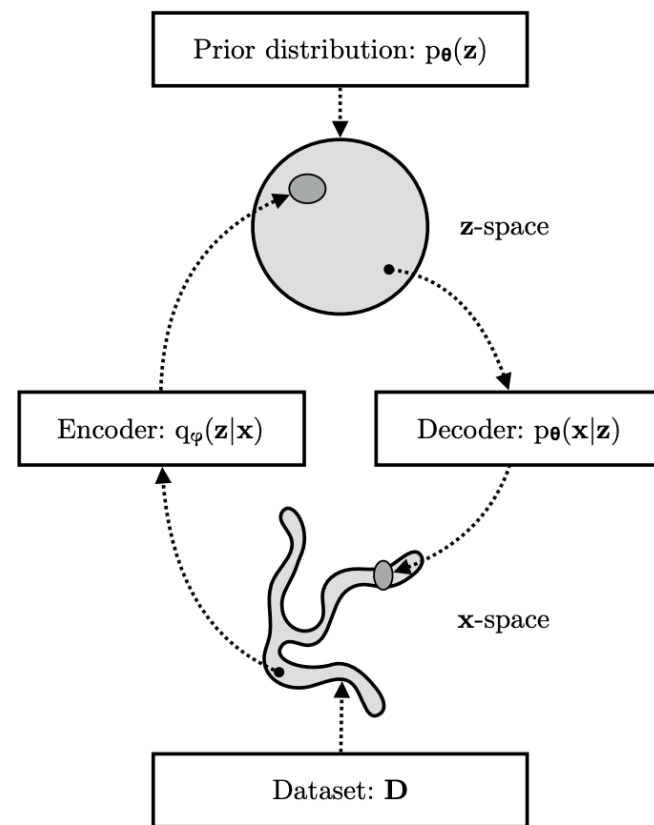

Kingma, D. P., & Welling, M. (2019). An Introduction to Variational Autoencoders. *Foundations and Trends® in Machine Learning*, 12(4), 307-392.



# Derivation of VAE objective (known as the evidence lower bound or ELBO)

- ▶  $\log p_g(x)$
- ▶  $= \mathbb{E}_{q_f} \left[ \log p_g(x) \right]$  ( $\mathbb{E}$  of constant = constant)
- ▶  $= \mathbb{E}_{q_f} \left[ \log \frac{p_g(x) p_g(z|x)}{p_g(z|x)} \right]$  (inflate)
- ▶  $= \mathbb{E}_{q_f} \left[ \log \frac{p_g(x, z) q_f(z|x)}{q_f(z|x) p_g(z|x)} \right]$  (inflate)
- ▶  $= \mathbb{E}_{q_f} \left[ \log \frac{p_g(x, z)}{q_f(z|x)} \right] + \mathbb{E}_{q_f} \left[ \log \frac{q_f(z|x)}{p_g(z|x)} \right]$
- ▶  $= \text{ELBO}(x; p_g, q_f) + KL(q_f(z|x), p_g(z|x))$
- ▶  $\Rightarrow \text{ELBO}(x; p_g, q_f) = \log p_g(x) - KL(q_f(z|x), p_g(z|x))$ 
  - ▶  $\leq \log p_g(x)$

Lower bound! Tight if  $q_f(z|x) = p_g(z|x)$

The ELBO can be interpreted as a reconstruction error term and a regularization term

$$\begin{aligned}
 \blacktriangleright \text{ELBO}(x; p_g, q_f) &= \mathbb{E}_{q_f} \left[ \log \frac{p_g(x, z)}{q_f(z|x)} \right] \\
 \blacktriangleright &= \mathbb{E}_{q_f} \left[ \log \frac{p_g(z) p_g(x|z)}{q_f(z|x)} \right] \\
 \blacktriangleright &= \mathbb{E}_{q_f} [\log p_g(x|z)] + \mathbb{E}_{q_f} \left[ \log \frac{p_g(z)}{q_f(z|x)} \right] \\
 \blacktriangleright &= \mathbb{E}_{q_f} [\log p_g(x|z)] - \mathbb{E}_{q_f} \left[ \log \frac{q_f(z|x)}{p_g(z)} \right] \\
 \blacktriangleright &= \mathbb{E}_{q_f} [\log p_g(x|z)] - \text{KL} \left( q_f(z|x), p_g(z) \right)
 \end{aligned}$$

▶ Minimizing the negative yields error + regularization

$$\min_{f,g} -\frac{1}{n} \sum_i \mathbb{E}_{q_f} [\log p_g(x_i|z_i)] + \text{KL} \left( q_f(z_i|x_i), p_g(z_i) \right)$$

Computable, see  
reconstruction error slides

Computable in closed-form for  
Gaussian distributions

Optimizing the ELBO objective does two things simultaneously

$$\min_{f,g} -\frac{1}{n} \sum_i \mathbb{E}_{q_f}[\log p_g(x_i|z_i)] + \text{KL}(q_f(z_i|x_i), p_g(z_i))$$

- ▶  $p_g$  - Optimize the lower bound on the likelihood
- ▶  $q_f$  - Improve the lower bound (i.e., make it tighter)

# Reparameterization trick allows us to compute gradients for $q_f$

$$\min_{f,g} -\frac{1}{n} \sum_i \mathbb{E}_{q_f} [\log p_g(x_i|z_i)] + \text{KL} \left( q_f(z_i|x_i), p_g(z_i) \right)$$

Computable in closed-form for Gaussian distributions

$$\min_{f,g} -\frac{1}{n} \sum_i \mathbb{E}_{\epsilon} [\log p_g(x_i|z_i = f(x_i) + \epsilon)] + \mathbb{E}_{\epsilon} \left[ \log \frac{q_f(f(x_i) + \epsilon|x_i)}{p_g(f(x_i) + \epsilon)} \right]$$

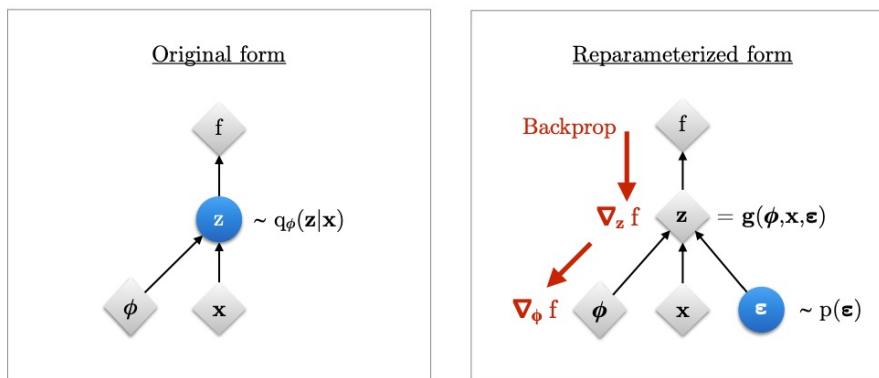

In this figure,  $f$  is the loss function,  $g$  is the reparameterization function, and  $\phi$  are the parameters of the encoder.

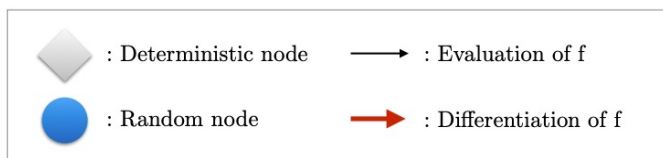

Kingma, D. P., & Welling, M. (2019). An Introduction to Variational Autoencoders. *Foundations and Trends® in Machine Learning*, 12(4), 307-392.

Putting it all together:

The VAE algorithm using SGD

1. Get minibatch of data  $x$
2. Pass through encoder to get  $\mu, \sigma^2 = f(x)$
3. Sample from  $z = q_f(z|x, (\mu, \sigma^2) = f(x))$  using reparametrization trick
4. Pass through decoder to get output parameters  $\theta = g(z)$
5. Compute log likelihood of  $p_g(x|z, \theta = g(z))$
6. Loss is negative log likelihood + KL term
7. Backpropagate to gradients for both  $g$  and  $f$  and update model

“Traditional” Drawback:  
VAEs tend to generate blurry images  
rather than sharp images



<https://github.com/WojciechMormul/vae>



# Maybe not a drawback... VQ-VAE-2 at *NeurIPS 2019*

Generated high-quality images  
(probably don't ask how long it  
takes to train this though...)

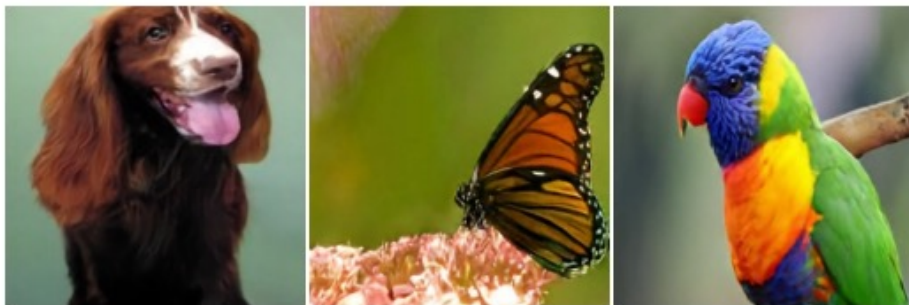

Razavi, A., van den Oord, A., & Vinyals, O.  
(2019). Generating diverse high-fidelity  
images with vq-vae-2. In *Advances in  
Neural Information Processing  
Systems* (pp. 14866-14876).

